



GENUINE PARTS

INSTALLATION INSTRUCTIONS

1. DESCRIPTION: Front Splash Guards

2. APPLICATION: Pathfinder / Frontier / Xterra

3. PART NUMBER: 999J2 XR00003 / 999J2 KR00003

4. KIT CONTENTS:

Item	Qty.	Description
A	1	Splashguard Front (Right)
B	1	Splashguard Front (Left)
C	8	M5 x 20mm Screws
D	1	Installation Instructions Replacement Template

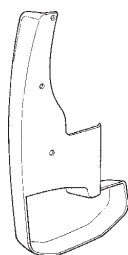

A

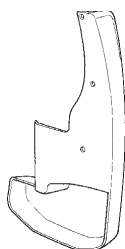

B



C



Important: Read Before Installation!

Dealer Installation Recommended.

▲ WARNING

To avoid serious personal injury or property damage, obtain the Installation Instructions before attempting to install this accessory. The Installation Instructions provide the necessary procedures for a safe installation.

CUSTOMER INTERNET DOWNLOAD INSTRUCTIONS: Customers can obtain Installation Instructions for Infiniti or Nissan vehicles at www.Infiniti-Techno.com or www.Nissan-Techno.com respectively. From the home page, click on "Inside Publications" and select Accessory Installations. Select your model and model year, then locate the Instructions for your accessory.

DEALER ASSIST DOWNLOAD INSTRUCTIONS: Dealership technicians can locate the Installation Instructions for this accessory in **ASST/INFO TOOLBOX**. Always download and use latest version of the Installation Instructions.

Installation Instructions Replacement Template: 999J2 XR00003 Rev. 09/2009

D

5. TOOLS REQUIRED:

#2 Phillips 90° Screwdriver
Rag

6. INSTALLATION PRECAUTIONS / SPECIAL NOTES:

- (A) Be careful not to damage the vehicle and the splash guards during the installation.
- (B) The splash guards are made of plastic. Avoid any heavy impact.
- (C) After the installation is complete, make sure all the screws, nuts, bolts and other components are tightened securely.
- (D) Installation surface must be clean.

INSTALLATION INSTRUCTIONS - Front Splash Guard

7. INSTALLATION PROCEDURE:

The procedure below shows the installation for the right side. Repeat the same procedure for the left side.

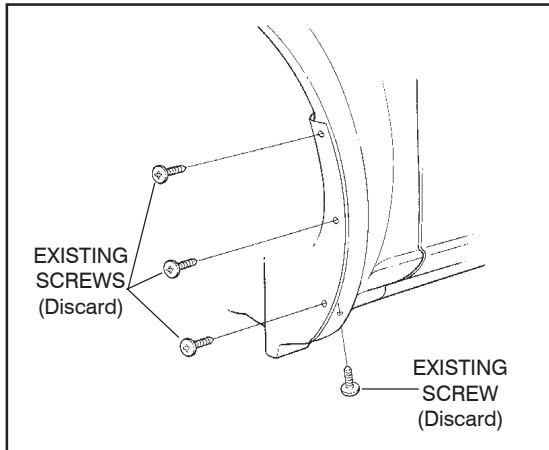

1. Removal of the screws from the vehicle

- Wash any dirt and oil off of the installation surface with mild soap and water.
- Remove the tapping screws (4 locations) and discard.

Important

Turn the tire to the right during the installation of the right side splash guard. (Turn the tire left during left side installation.)

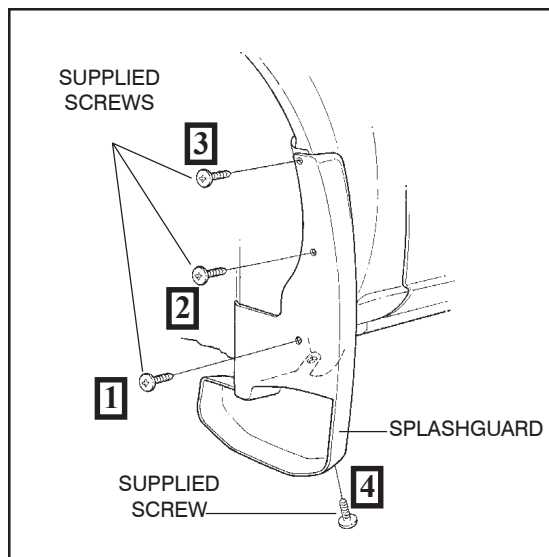

2. Front splashguard installation

- Install the front splashguard with supplied tapping screws. Push upwards, rearward and inward while tightening screws.
- Tighten screws in sequence shown. **Do not over tighten.**

Important

Hold the splash guard tight to the vehicle while tightening the screws. Be sure no gap occurs between lower panel and splash guard.